

MAE MANUFACTURERS cc

MANUFACTURERS OF THE MAE FLAMEPROOF ALTERNATOR AND ELECTRICAL FLAMEPROOF EQUIPMENT

REG NO: CK 95/47371/23 VAT NO: 447 011 0034

Tel: +27 (11) 421 5551

Fax: +27 (11) 421 5618

E-mail: orders@maesa.co.za / admin@maesa.co.za

MAE Flameproof Cluster Lamp

Part No: MAEFC



Product Features

- ❖ 12 or 24 Volts.
- ❖ Flameproof.
- ❖ Cushion Mount Bulb.
- ❖ External Adjustable Lamp Angle.
- ❖ Lux Intensity Over 20 Lux at 20Mt.
- ❖ Seal Beam Halogen.
- ❖ Available with LED Headlights.

Technical Specifications

Input Max

4.16 Amps

Input Voltage

12V or 24V

Certificate

MASC M/13-644X (RSA)

ANZEx 14.4135X (AUS)

CML 14 ATEX 1022 (EUROPE)

Weight

20kg

Overall Length

270mm

Overall Diameter

255mm

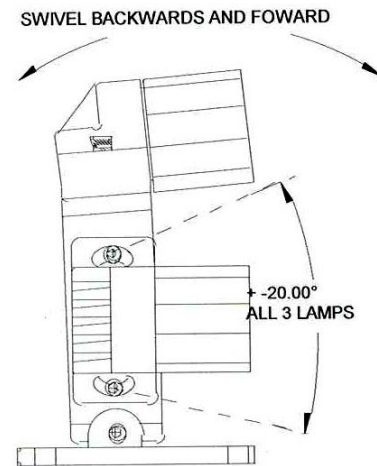
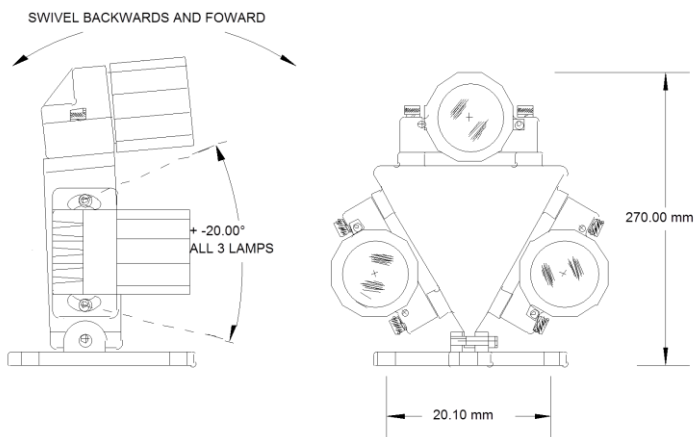

MAXIMUM TEMPERATURE ON EACH LAMP LENS DOES NOT EXCEED 110°C



Members: M. Lo Giudice; G. Lo Giudice;

MAE MANUFACTURERS cc

MANUFACTURERS OF THE MAE FLAMEPROOF ALTERNATOR AND ELECTRICAL FLAMEPROOF EQUIPMENT









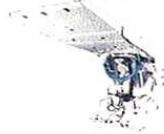

REG NO: CK 95/47371/23 VAT NO: 447 011 0034

Tel: +27 (11) 421 5551

Fax: +27 (11) 421 5618

E-mail: orders@maesa.co.za / admin@maesa.co.za

Application

 SCOOP		 QUARRY VEHICLES		 LONG WALL SHIELD	
 CONTINUOUS MINER		 SHUTTLE CAR		 HAULAGE	
 DUMP TRUCK		 DRILLS		OTHER APPLICATIONS	

Lux Intensity

Face at 10mt from Cluster Lamp. Each block represents 1m x 1m. All figures in LUX.

Disclaimer

The information in this specification is derived from the latest model available at the time of issue 1.0. While every precaution has been taken to ensure the accuracy of the content, no responsibility can be accepted for any errors or omissions nor any misinterpretation or misapplication. MAE has adopted a continuous product improvement policy and therefore, specifications are subject to change without prior notice © September 2009 MAE all rights reserved.



FLAMEPROOF CLUSTER LAMP

PART NO. : MAEFC (CLUSTER)
 PART NO. : MAEFL001224 (HEAD)
 MODEL: 1A
 IA NO. SABS M/P 570
 Ex dt 150°C



SABS APPROVED
 FLP Exd CABLE GLAND
 GLAND SIZE 1-25

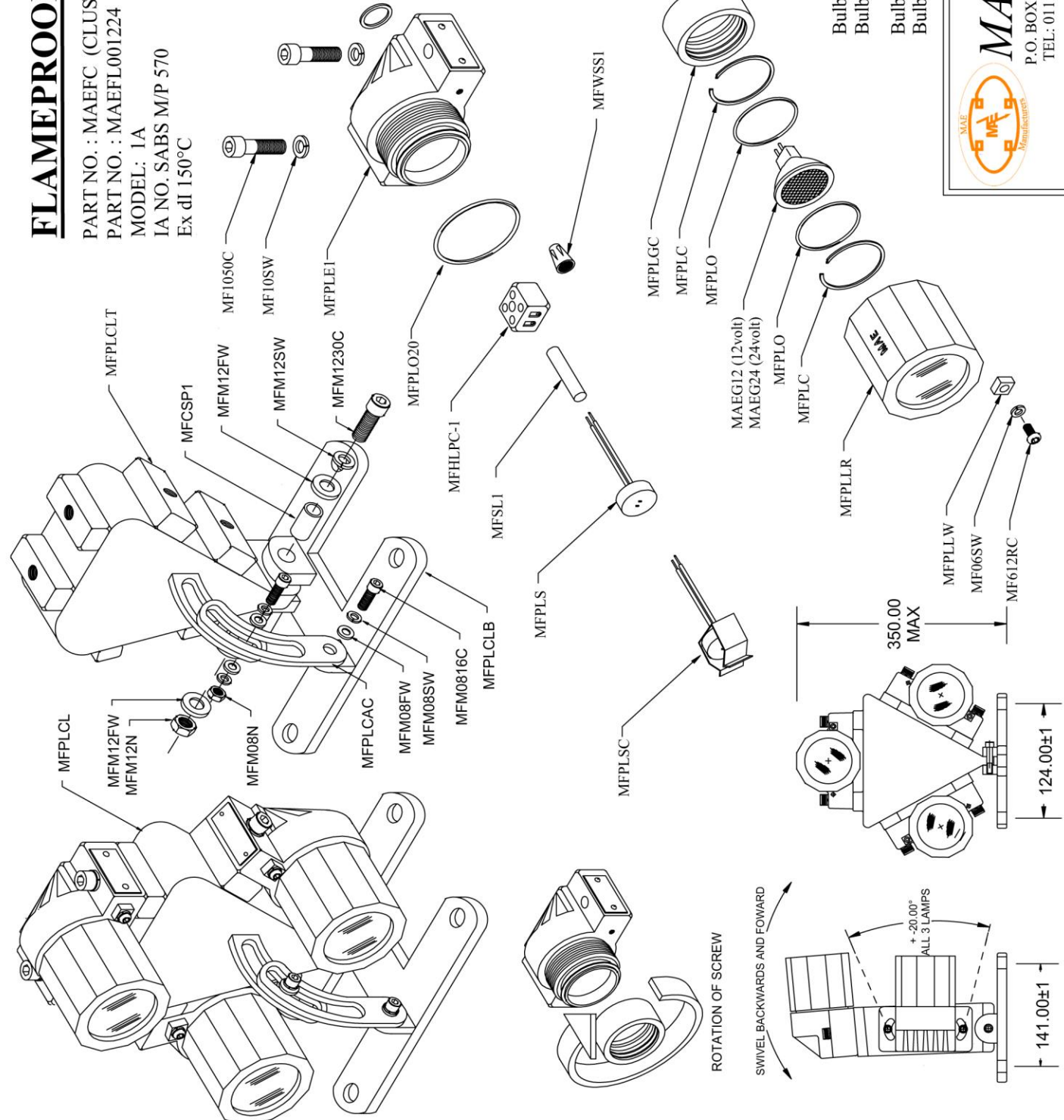

ELECTRICAL

Bulb type MR-16 with (Lens) only
 Bulb Voltage : 12 or 24 volt AC or DC
 Bulb Wattage : 50 watts QH
 Bulb Amperage : 4.16 amps.

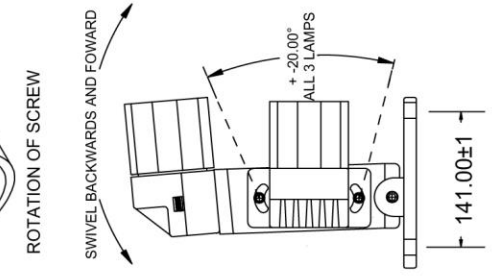

MAE MANUFACTURERS
 P.O. BOX 402 BENONI 1500 SOUTH AFRICA
 TEL: 011 421-5551 FAX : 011 421 5618

Servicing Mining Around the World